

DESIGN AND IMPLEMENTATION OF A LIVE HEART BLOCKAGE PREDICTION DEVICE USING ARTIFICIAL INTELLIGENCE AND MACHINE LEARNING

Urjita A. Barapatre

B. Tech, Student, Electronics and
Telecommunication Engg.

Guru Nanak Institute of
Engineering and Technology
Nagpur-441501

urjita12patre@gmail.com

Mrunali P. Badwaik

B. Tech, Student, Electronics and
Telecommunication Engg.

Guru Nanak Institute of
Engineering and Technology
Nagpur-441501

mrunalibadwaik2805@gmail.com

Anurag A. Kaware

B. Tech, Student, Electronics and
Telecommunication Engg.

Guru Nanak Institute of
Engineering and Technology
Nagpur-441501

anuragkaware636@gmail.com

Anjali P. Tekade

B. Tech, Student, Electronics and
Telecommunication Engg.

Guru Nanak Institute of
Engineering and Technology
Nagpur-441501

anjali.tekade18@gmail.com

Prof. Shubham Kanojiya

Assistant Professor, Electronics and
Telecommunication Engg.

Guru Nanak Institute of Engineering
and Technology Nagpur-441501

shubhamkanojiya011@gmail.com

ABSTRACT

The project titled "Live Heart Blockage Prediction Device Using AI/ML" focuses on developing a real-time, intelligent system for early detection of heart-related risks. The system acquires ECG signals from the human body using electrodes and an AD8232 ECG sensor, which are processed by an ESP32 microcontroller and transmitted for analysis. The collected data is preprocessed, filtered, and subjected to feature extraction and anomaly detection to identify abnormal heart patterns. Machine learning algorithms such as Random Forest, Support Vector Machine, and Neural Networks are used to accurately predict the risk of heart blockage. The results are displayed in real-time on a monitoring interface, enabling continuous tracking of heart activity. This system provides a cost-effective, portable, and efficient solution that supports early diagnosis and assists healthcare professionals in making informed decisions, thereby improving patient outcomes.

Keywords: ECG, Heart Blockage Prediction, Artificial Intelligence, Machine Learning, ESP32, Support Vector Machine, Neural Networks, AD8232 ECG sensor.

INTRODUCTION.

Rapid changes in lifestyle, increasing stress levels, and unhealthy dietary habits have significantly increased the incidence of cardiac disorders worldwide. Among these disorders, coronary artery blockage is one of the most critical conditions that can lead to severe cardiac complications if not detected at an early stage. Cardiovascular diseases (CVDs) remain one of the leading causes of mortality globally and are responsible for a substantial number of premature deaths each year.

Coronary artery blockage develops when fatty deposits, cholesterol, and plaque accumulate within the coronary arteries, resulting in narrowing or obstruction of blood vessels. This condition restricts the supply of oxygen-rich blood to the heart muscle and may cause symptoms such as chest pain, shortness of breath, irregular heartbeat, or myocardial infarction in severe cases. Therefore, continuous monitoring and early detection of abnormal cardiac activity are essential to reduce the risk of life-threatening complications.

Electrocardiography (ECG) is a widely used non-invasive diagnostic technique that records the electrical activity of the heart during each cardiac cycle. A standard ECG waveform consists of three major components: the P wave (atrial depolarization), the QRS complex (ventricular depolarization), and the T wave (ventricular repolarization). Variations in the amplitude, duration, and morphology of these waveform components can indicate underlying cardiac abnormalities, including ischemia and blockage-related conditions. Detailed waveform analysis provides deeper clinical insight compared to simple heart rate monitoring.

Conventional ECG machines used in hospitals provide high accuracy and multi-lead monitoring; however, they are expensive, bulky, and confined to clinical environments. On the other hand, most IoT-based health monitoring systems primarily measure heart rate in beats per minute (BPM) and generate alerts when predefined thresholds are exceeded. Such systems do not analyze detailed waveform characteristics and therefore lack predictive capability for early blockage detection.

To overcome these limitations, this research proposes a portable and intelligent ECG monitoring system integrated with Artificial Intelligence (AI) and Machine Learning (ML) techniques. The system captures real-time ECG signals and applies supervised learning algorithms to analyze waveform features associated with coronary blockage. By extracting relevant parameters such as interval durations and amplitude variations, the proposed device aims to provide early predictive alerts, enabling timely medical intervention and reducing the risk of severe cardiac events.

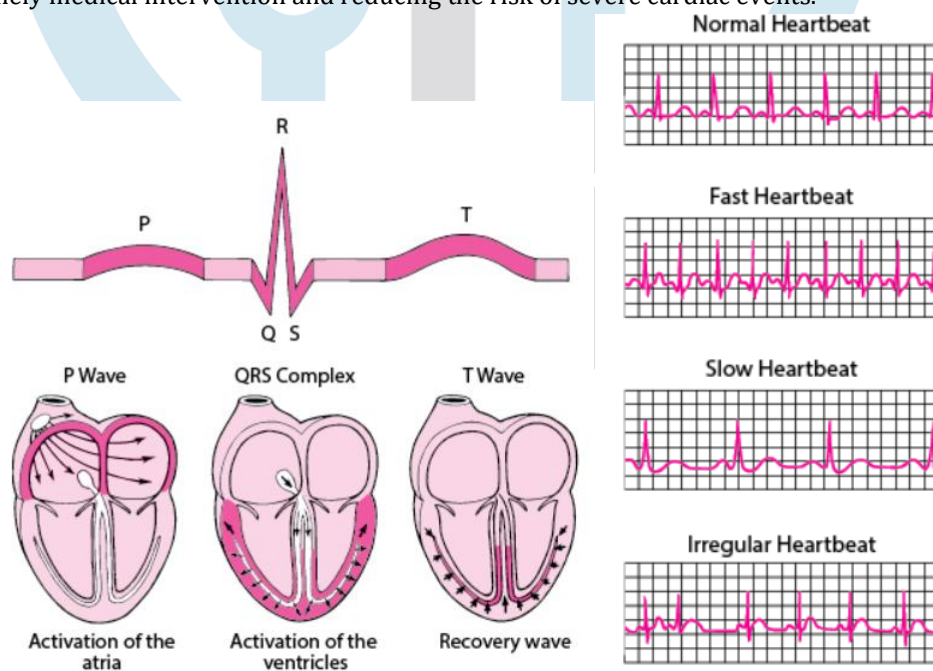

LITERATURE REVIEW

[18] A. Patil, A.; Sutar, S.; Malwade, I. *IoT Based Heart Attack Detection and Heart Rate Monitor*. International Journal for Research in Applied Science & Engineering Technology (IJRASET), 2023, 11(6). <https://doi.org/10.22214/ijraset.2023.53679>

The study by Patil et al. proposed an IoT-based heart attack detection and heart rate monitoring system using a pulse sensor, ATmega328 microcontroller, and GSM module. The system continuously monitors the patient's heartbeat and compares it with predefined threshold values. If the heartbeat exceeds or falls below the set limit, an alert message is sent to registered contacts through GSM. The hardware architecture includes a pulse sensor, microcontroller, LCD display, and GSM module for real-time monitoring and emergency notification. The system aims to reduce death rates by enabling remote patient monitoring and quick medical response. However, the system primarily relies on heart rate thresholds and does not incorporate advanced ECG signal analysis or intelligent prediction mechanisms.

[17] Khatoon, S.; Khalid, S.S.; Tariq, W.; Tanweer, S.; Rao, N. *Real-Time ECG Monitoring Device With Heart Pulse Sensor*. ICIDSSD 2020, EAI, 2021. DOI: 10.4108/eai.27-2-2020.2303170 <https://eudl.eu/doi/10.4108/eai.27-2-2020.2303170>

Khatoon et al. presented a real-time ECG monitoring system using the AD8232 ECG sensor module integrated with an Arduino Uno microcontroller. The system collects ECG signals using three electrodes placed on the body and processes the signals to display ECG waveforms. The device allows both online and offline monitoring of ECG signals and detects abnormal pulse rates such as bradycardia and tachycardia. The ECG signal conditioning stage improves signal clarity by filtering noise and motion artifacts. Although the system provides accurate ECG waveform visualization and basic abnormality detection, it lacks predictive analytics and advanced classification methods for early heart blockage detection.

[2] Anshu, A.K.; Bando, A.P.; Shree, C. *Heartbeat Monitoring and Heart Attack Detection using IoT (Internet of Things)*. International Research Journal of Engineering and Technology (IRJET), 2020, 7(4). <https://www.irjet.net/archives/V7/i4/IRJET-V7I4207.pdf>

Anshu et al. proposed a heartbeat monitoring system based on IoT using a pulse sensor, Arduino microcontroller, and Wi-Fi module. The system measures heart rate and transmits the data to an online server and Android application for remote monitoring. The transmitting and receiving circuits are designed to generate alerts when the heartbeat crosses predefined thresholds. The system is portable, cost-effective, and suitable for home-based monitoring. However, similar to other IoT-based systems, it depends only on heart rate measurements and does not utilize ECG waveform features or machine learning techniques for precise heart attack prediction.

[16] Deepika; Shubhangi, D.C. *The Heart Attack Detection System and Reporting over Web Server using Arduino Mega & Node MCU*. International Journal for Research in Applied Science & Engineering Technology (IJRASET), 2020, 8(7). <https://doi.org/10.22214/ijraset.2020.30331>

Deepika and Shubhangi proposed a heart attack detection system integrated with Arduino Mega 2560 and ESP8266 Node MCU for cloud-based reporting. The system utilizes multiple sensors including heart rate sensor, temperature sensor, skin resistance sensor, GSM, and GPS modules. When abnormal conditions are detected, the system sends the patient's location and emergency alert via SMS and uploads data to a web server. This multi-parameter monitoring improves reliability compared to single-parameter systems. However, the system still operates on threshold-based detection and does not implement intelligent ECG signal analysis or AI-based prediction techniques.

PROPOSED SYSTEM ARCHITECTURE

The proposed system is designed to capture real-time ECG signals and perform predictive analysis using machine learning algorithms. The architecture consists of both hardware and software components integrated to ensure reliable performance. The hardware section includes an AD8232 ECG sensor module, which captures electrical signals from body electrodes placed on the chest and limbs. The module amplifies and filters the weak ECG signals before transmitting them to the ESP32 microcontroller. The ESP32 serves as the central processing unit of the system and performs analog-to-digital conversion of the ECG signal. Due to its dual-core processor and integrated communication features, the ESP32 is well-suited for real-time biomedical signal processing. A voltage regulator ensures stable power supply to sensitive components, while an OLED display provides real-time visualization of the ECG waveform. The processed data is transmitted via serial communication to a desktop AI/ML application for advanced analysis.

Component Name	Description	Function in System
AD8232 ECG Sensor Module	Single-lead ECG analog front-end	Captures and conditions ECG signals
ESP32 Microcontroller	32-bit dual-core Wi-Fi + Bluetooth MCU	Signal processing & data transmission
ECG Electrodes	Biomedical disposable electrodes	Detect cardiac electrical impulses
0.96" OLED Display (SSD1306)	I2C-based graphical display module	Displays ECG waveform & risk output
LM7805 Voltage Regulator	5V linear regulator IC	Provides stable power supply
Jumper Wires & PCB	Circuit interconnections	Hardware integration
Power Supply / Battery	5V regulated source	Powers entire system

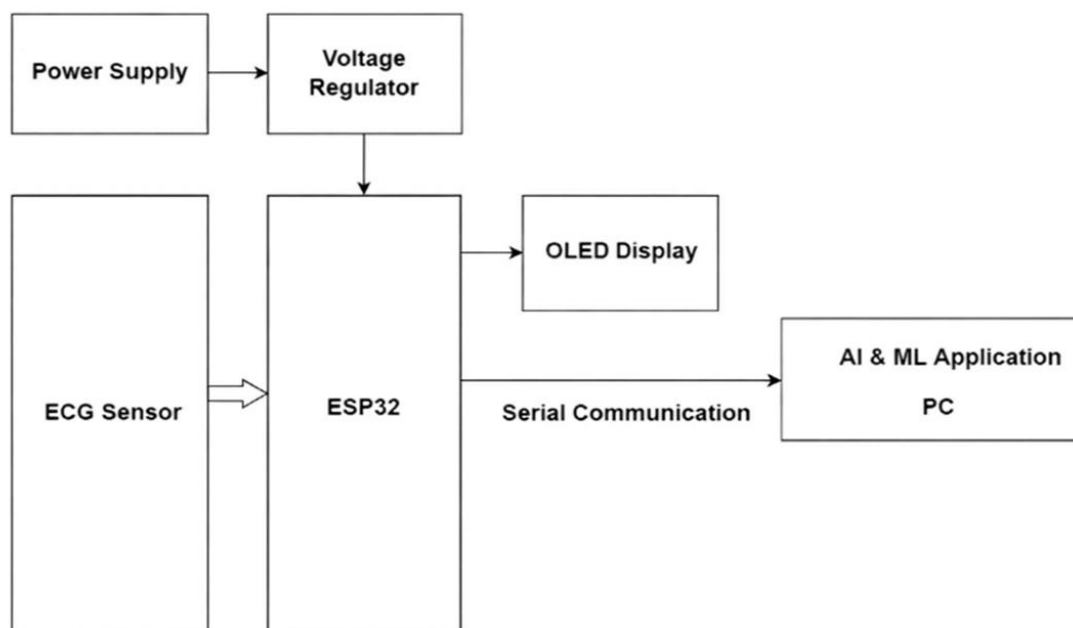

Fig 1. Block Diagram of Hardware Components

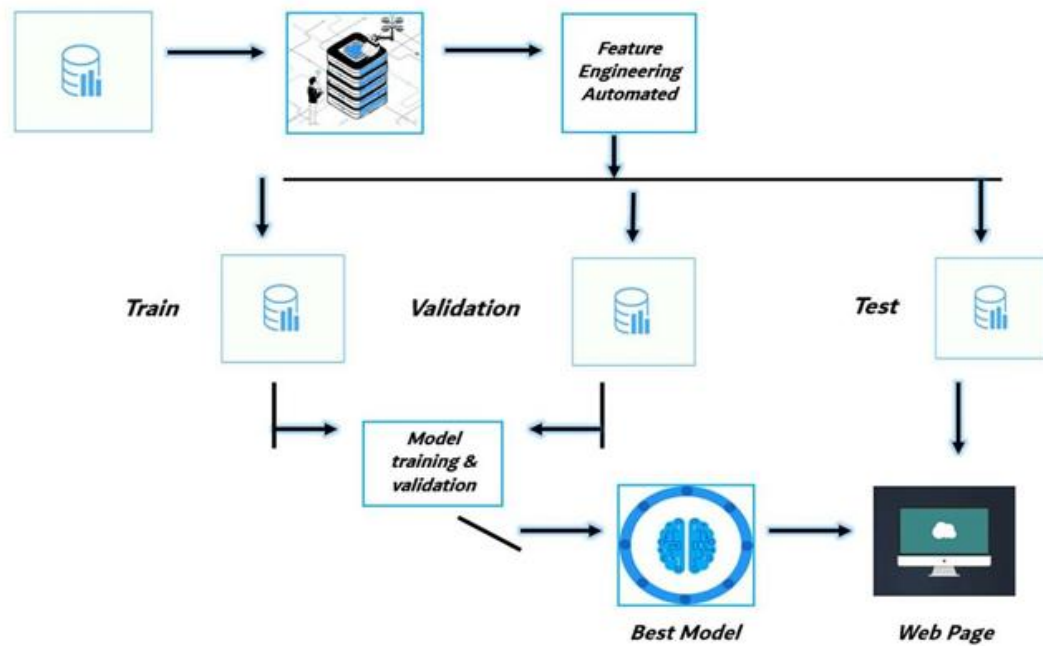

Fig 2. Block Diagram of Software Procedure

METHODOLOGY

The methodology of the proposed system follows a systematic pipeline starting from data acquisition to final deployment. Initially, heart-related data is collected from multiple reliable sources such as medical datasets, ECG sensor readings, and patient records. This raw data is then preprocessed to improve quality by handling missing values, removing noise, normalizing features, and converting categorical data into numerical form. Feature engineering and selection techniques are applied to identify the most relevant attributes affecting heart disease prediction. Additionally, anomaly detection methods such as Isolation Forest and One-Class SVM are used to identify abnormal patterns in ECG signals, which helps in early detection of potential heart issues.

After preprocessing, machine learning models are developed using supervised, unsupervised, and deep learning techniques. Algorithms like Random Forest, SVM, and Neural Networks are trained on the processed dataset to classify heart disease risk. The models are evaluated using performance metrics such as accuracy, precision, recall, and F1-score along with cross-validation techniques to ensure reliability. Once the best-performing model is selected, it is integrated with the hardware system consisting of ESP32 and ECG sensor for real-time monitoring. The final system continuously analyzes incoming ECG data, predicts heart blockage risk, and displays results through an interface, enabling early diagnosis and assisting healthcare professionals in decision-making.

WORKING PRINCIPLE

The system works by continuously acquiring electrical signals of the heart using ECG electrodes (red, yellow, and green) placed on the patient's body, which are sensed by the AD8232 ECG sensor and converted into analog signals. These signals are then sent to the ESP32 microcontroller, where they are digitized, filtered, and transmitted to a processing unit (Python-based AI/ML system) via communication protocols like Wi-Fi or serial communication. The received data undergoes preprocessing such as noise removal and normalization, followed by feature extraction and anomaly detection to identify irregular heart patterns. Machine learning models like Random Forest, SVM, or Neural Networks analyze these patterns to predict the risk of heart blockage. Finally, the results are displayed in real-time on an OLED or web interface, enabling early detection and assisting doctors in making accurate decisions.

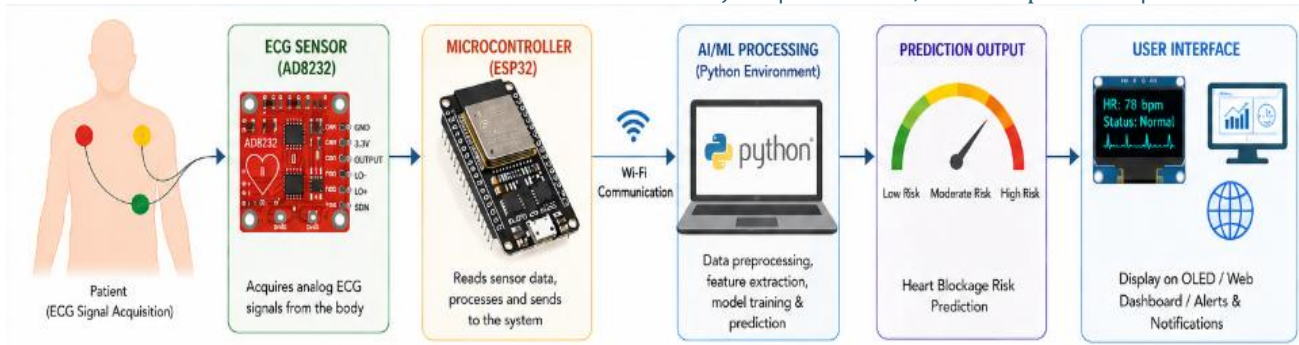

RESULTS

The developed prototype successfully captured real-time ECG waveforms and displayed them on the OLED interface. The machine learning model analyzed waveform features and accurately classified normal and abnormal patterns under controlled testing conditions. Compared to threshold-based BPM monitoring systems, the proposed system demonstrated enhanced predictive capability by analyzing waveform morphology. The integration of AI significantly improved early detection potential and reduced dependency on fixed threshold logic.

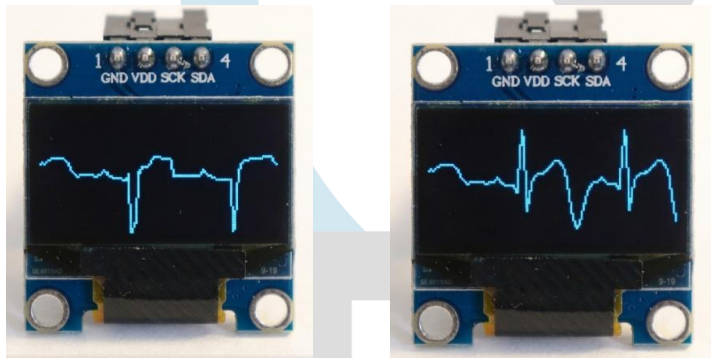

CONCLUSION

This paper presented the design and implementation of a Live Heart Blockage Prediction Device using Artificial Intelligence and Machine Learning. The system integrates ECG waveform acquisition with predictive analytics to provide early warnings of potential cardiac risks. Unlike conventional IoT-based systems that rely solely on heart rate thresholds, the proposed device performs detailed waveform analysis and classification. The system is portable, cost-effective, and suitable for continuous monitoring applications. By transitioning from reactive alert systems to predictive healthcare solutions, the proposed device contributes to advancements in smart biomedical instrumentation.

FUTURE SCOPE

The system can be enhanced by integrating wearable IoT devices and cloud-based platforms for continuous remote monitoring and real-time data analysis.

Advanced AI models and larger datasets can further improve prediction accuracy and enable personalized healthcare solutions.

REFERENCES

1. Nikunj Patel et al., Heart Attack Detection and Heart Rate Monitoring Using IoT, 2018. <https://www.scribd.com/document/420716023/Heart-Attack-Detection-and-Heart-Rate-Monitoring-Using-IoT?utm>
2. Abhishek Kumar Anshu et al., Heartbeat Monitoring and Heart Attack Detection using IoT, IRJET, 2020. <https://www.irjet.net/archives/V7/i4/IRJET-V7I4207.pdf>
3. Bandana Mallick and Ajit Kumar Patro, Heart Rate Monitoring System Using Fingertip Through Arduino, IJSETR, 2016. <https://www.irjet.net/archives/V7/i4/IRJET-V7I4207.pdf>
4. IoT Based Heart Attack Detection and Heart Rate Monitor, IJRASET, 2023. <https://www.ijraset.com/best-journal/iot-based-heart-attack-detection-and-heart-rate-monitor?>
5. Shivam Patel and Yogesh Chauhan, Heart Attack Detection using Motion Sensing Device, 2014. https://irjet.com/common_src/article_file/1593586269_1b72e0f9c8_4_irjet.pdf
6. Monalisa Akter, Nayeema Islam, Abdul Ahad, Md. Asaduzzaman Chowdhury, Fahim Foysal Apurba and Riasat Khan *An Embedded System for Real-Time Atrial Fibrillation Diagnosis Using a Multimodal Approach to ECG Data. <https://www.mdpi.com/2673-4117/5/4/143>
7. AminUllah 1,2, Syed Muhammad Anwar 1,2 , Muhammad Bilal 3 and Raja Majid Mehmood 4_Classification of Arrhythmia by Using Deep Learning with 2-D ECG Spectral Image Representation <https://arxiv.org/abs/2005.06902>
8. Makhdoma Haider 1,*, Manzoor Hussain 2 and Gina Purnama Insany_Heart Attack Prediction Using Machine Learning Models: A Comparative Study of Naive Bayes, Decision Tree, Random Forest, and K-Nearest Neighbors <https://www.mdpi.com/2673-4591/107/1/121>
9. Yaqoob Ansari1*, Omar Mourad2, Khalid Qaraq1 and Erchin Serpedin3_Deep learning for ECG Arrhythmia detection and classification: an overview- <https://www.frontiersin.org/journals/physiology/articles/10.3389/fphys.2023.1246746/full>
10. Dr. Meena Tiwari1 , Akhilesh A. Wao 2_HEART ATTACK DETECTION BY HEART RATE MONITORING USING IOT

11. Adedayo Ogunpola 1, Faisal Saeed 1,* , Shadi Basurra 1, Abdullah M. Albarrak 2 1 and Sultan Noman Qasem_Machine Learning-Based Predictive Models for Detection of Cardiovascular Diseases. <https://www.mdpi.com/search?q=Machine+Learning+Based+Predictive+Models+for+Detection+of+Cardiovascular+Diseases>
12. Ziad O. Abu-Faraj, Walid Al Chamaa, Anthony Al Hadchiti, Yehya Sraj, Joe Tannous_Design and Development of a Heart-Attack Detection Steering Wheel <https://ieeexplore.ieee.org/search/searchresult.jsp?newsearch=true&queryText=Design%20and%20Development%20of%20a%20Heart-Attack%20Detection%20Steering%20Wheel>
13. K.Y. Rokde, S.S. Shende, S.M. Ghatole, P.B. Dahikar_An Embedded System for Patient Heartbeat Monitoring <https://www.ijert.org/search-engine-optimization-?q=An%20Embedded%20System%20for%20Patient%20Heartbeat%20Monitoring>
14. K. UMAPATHY, SHIVA KUMAR, S. DEEPAK NANDAN, V. JAGADEESWARA GUPTHA, SANJEET KUMAR, ECE Department, SCSVMV UNIVERSITY, ENATHUR, KANCHIPURAM_HEART RATE MONITORING SYSTEM USING FINGER TIP THROUGH ARDUINO <https://ijsetr.com/search?q=Heart%20Rate%20Monitoring%20System%20Using%20Fingertip%20Arduino>
15. Deepika; Shubhangi, D.C. *The Heart Attack Detection System and Reporting over Web Server using Arduino Mega & Node MCU*. International Journal for Research in Applied Science & Engineering Technology (IJRASET), 2020, 8(7). <https://doi.org/10.22214/ijraset.2020.30331>
16. Khatoon, S.; Khalid, S.S.; Tariq, W.; Tanweer, S.; Rao, N. *Real-Time ECG Monitoring Device With Heart Pulse Sensor*. ICIDSSD 2020, EAI, 2021. DOI: 10.4108/eai.27-2-2020.2303170 <https://eudl.eu/doi/10.4108/eai.27-2-2020.2303170>
17. A. Patil, A.; Sutar, S.; Malwade, I. *IoT Based Heart Attack Detection and Heart Rate Monitor*. International Journal for Research in Applied Science & Engineering Technology (IJRASET), 2023, 11(6). <https://doi.org/10.22214/ijraset.2023.53679>