

Proximity-Aware Human Detection and Electrical Hazard Mitigation near Power Lines Using IoT Integrated Microwave Radar

Pardhavi Sai Sree.T

Assistant Professor

Electrical and Electronics Engineering

School of Engineering and Technology, Sri Padmavathi Mahila Visvavidyalayam, Tirupati

pardhavi03@gmail.com

Abstract— this paper presents a proximity-aware safety system for detecting human presence and preventing electrical hazards near power transmission lines using IoT-integrated microwave radar. The system utilizes a microwave radar sensor to continuously monitor motion and estimate the distance of a person from high-voltage infrastructure. The sensed data is processed by a microcontroller to perform signal conditioning, motion detection, and proximity evaluation. A threshold-based decision mechanism is implemented to assess potential risk levels. When a hazardous condition is identified, the system activates alert mechanisms such as buzzers, LEDs, and warning indicators. Simultaneously, real-time data is transmitted to a cloud platform for remote monitoring through mobile or web applications. The proposed design ensures reliable operation in various environmental conditions where optical systems may fail. It offers low-cost implementation with efficient energy usage. Experimental observations indicate improved detection accuracy and quick response time. The system provides an effective solution for enhancing safety in power transmission environments.

Key Words—Internet of Things (IoT), Microwave Radar, Human Detection, Electrical Hazard Mitigation, Power Line Safety, Real-Time Monitoring.

I. INTRODUCTION

Electrical hazards associated with high-voltage power transmission lines remain a critical safety concern for workers and the general public. Accidental human contact or unsafe proximity to energized conductors can lead to severe injuries or fatalities. Conventional safety measures such as warning boards, insulation, and physical barriers provide only passive protection and depend heavily on human awareness. In many real-world situations, especially in outdoor or remote environments, continuous monitoring is not feasible. As a result, there is a growing need for intelligent systems capable of actively detecting human presence and preventing hazardous incidents. Advances in sensing technologies and embedded systems offer new opportunities to enhance safety standards. In this context, integrating smart detection mechanisms becomes essential for modern electrical infrastructure.

Recent developments in the Internet of Things (IoT) have enabled real-time monitoring and communication across distributed systems. IoT-based safety solutions can collect data from sensors, process it locally or remotely, and provide timely alerts to users. However, many existing systems rely on vision-based or infrared sensing techniques, which are often affected by environmental conditions such as fog, rain, and poor lighting. These limitations reduce their reliability in outdoor applications, particularly near power transmission lines. Microwave radar technology presents a robust alternative, as it can detect motion and presence irrespective of visibility conditions. By leveraging radar sensing, it is possible to achieve more consistent and accurate human detection. This makes it suitable for safety-critical environments where reliability is a priority.

Microwave radar sensors operate by transmitting electromagnetic waves and analyzing the reflected signals from objects in their vicinity. When a human enters the detection zone, variations in the reflected signal can be processed to determine motion and approximate distance. By integrating such sensors with microcontrollers, real-time signal processing and decision-making can be achieved. The inclusion of threshold-based proximity evaluation allows the system to assess risk levels and trigger appropriate responses. Furthermore, combining this setup with IoT connectivity enables remote monitoring and data logging through cloud platforms. This integration ensures that alerts are not only generated locally but also communicated to concerned personnel instantly. Such a system significantly improves situational awareness and response efficiency.

In this paper, a proximity-aware safety system based on IoT-integrated microwave radar is proposed to mitigate electrical hazards near power lines. The system is designed to detect human presence, evaluate proximity to high-voltage sources, and activate alert mechanisms when necessary. It incorporates sensing, processing, communication, and alert units into a unified framework. The proposed approach emphasizes reliability, low cost, and scalability for practical deployment in real-world environments. By addressing the limitations of existing methods, the system provides a more effective solution for electrical safety. The remaining sections of this paper discuss the system design, methodology, experimental results, and potential future improvements.

II. RELATED WORK

Human detection and safety monitoring systems have been widely studied using various sensing technologies. Traditional approaches primarily rely on infrared (IR) sensors and vision-based systems for detecting human presence. While these methods are effective in controlled environments, their performance is significantly affected by external factors such as lighting conditions, weather variations, and obstructions. Camera-based systems also involve higher computational complexity and raise concerns related to privacy and continuous monitoring, limiting their suitability for outdoor safety applications near power transmission lines.

To overcome these limitations, microwave and millimetre-wave radar technologies have been explored for robust human detection. Radar-based systems operate by transmitting electromagnetic waves and analysing the reflected signals to identify motion and presence. Previous studies have demonstrated that Doppler radar sensors can reliably detect human movement even in low-visibility conditions such as fog, smoke, or darkness. These systems offer advantages in terms of environmental adaptability and consistent performance, making them suitable for safety-critical applications where reliability is essential.

In parallel, the adoption of Internet of Things (IoT) technology has enabled the development of smart monitoring systems capable of real-time data acquisition and remote supervision. IoT-based frameworks facilitate communication between sensors, processing units, and cloud platforms, allowing instant alert generation and system control. Several research efforts have focused on integrating IoT with sensing devices for applications such as smart homes, industrial safety, and environmental monitoring. However, many of these systems emphasize connectivity and monitoring without incorporating accurate proximity detection mechanisms required for hazard prevention.

Despite the progress in radar sensing and IoT-based systems, limited work has been reported on their combined application for electrical hazard mitigation near power lines. Existing solutions often address either human detection or remote monitoring independently, without providing a unified framework for real-time risk assessment and alert generation. The lack of integrated systems that can accurately detect human proximity and respond promptly to hazardous conditions highlights a significant research gap. The proposed work aims to address this gap by combining microwave radar sensing with IoT technology to develop a reliable and efficient safety system for power transmission environments.

III. EXISTING SYSTEM

Traditional systems for human detection and safety near power transmission lines rely on technologies such as infrared (IR) sensors, ultrasonic sensors, and camera-based monitoring. IR sensors detect motion based on heat signatures, but their performance is highly influenced by environmental conditions like temperature variations and sunlight interference. Similarly, ultrasonic sensors provide limited range and are not suitable for large outdoor environments. Camera-based systems offer visual monitoring but require continuous image processing, which increases computational complexity and power consumption.

In addition, vision-based approaches depend heavily on proper lighting conditions and are less effective during night time, fog, or heavy rain. These systems also raise privacy concerns and require large data storage for video recordings. Another limitation of existing methods is the lack of real-time alert mechanisms integrated with remote monitoring platforms. Most conventional systems function as stand-alone units without connectivity, making it difficult to track and respond to hazards instantly.

Furthermore, existing safety measures near power lines, such as warning signs and physical barriers, are passive in nature and depend on human awareness. These approaches do not actively detect or prevent hazardous situations. As a result, there is a need for a more reliable, intelligent, and automated system that can detect human presence accurately and provide timely alerts regardless of environmental conditions.

IV. PROPOSED SYSTEM

The proposed system introduces a proximity-aware safety solution using IoT-integrated microwave radar for detecting human presence near power transmission lines. The system utilizes a microwave radar sensor to continuously monitor the surrounding environment and detect motion based on reflected electromagnetic signals. Unlike traditional sensors, microwave radar operates effectively under all weather and lighting conditions, ensuring reliable performance in outdoor environments.

The radar sensor is connected to a microcontroller (such as ESP32), which processes the received signals and determines the presence and approximate distance of a human. A threshold-based proximity evaluation method is implemented to assess whether the detected object is within a hazardous range. When the distance falls below a predefined safety limit, the system identifies it as a potential risk.

Upon detecting a hazardous condition, the microcontroller activates alert mechanisms such as a buzzer and LED indicators to warn nearby individuals. Simultaneously, the system transmits real-time data to a cloud-based IoT platform using wireless communication. This enables remote monitoring through mobile or web applications, allowing authorities to take immediate action if required. The proposed system is cost-effective, scalable, and suitable for deployment in various power transmission environments.

V. SYSTEM ARCHITECTURE

The system architecture is designed to provide a comprehensive framework for real-time human detection and electrical hazard mitigation near power transmission lines. It is organized into four major functional units: sensing unit, processing unit, alert and mitigation unit, and IoT monitoring unit. These units operate in coordination to ensure continuous monitoring, accurate decision-making, and timely response.

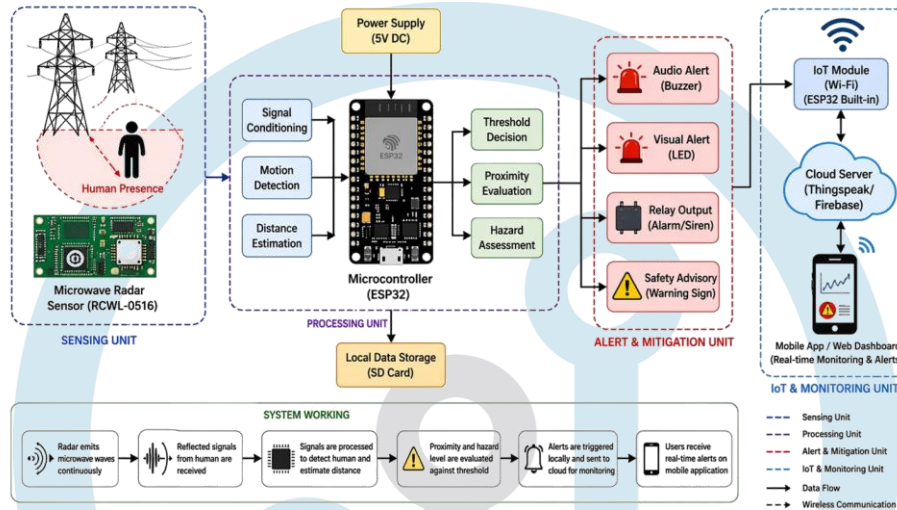

Figure 1: System Diagram

The **sensing unit** consists of a microwave radar sensor (RCWL-0516), which continuously emits microwave signals into the surrounding environment. When a human enters the detection zone, the reflected signals are captured and used to identify motion and presence. The sensor is capable of operating effectively under varying environmental conditions, making it suitable for outdoor applications near power lines.

The **processing unit** is implemented using a microcontroller (ESP32), which acts as the central control system. It receives raw signals from the radar sensor and performs signal conditioning, motion detection, and distance estimation. Based on these processed inputs, the system executes proximity evaluation and hazard assessment using predefined threshold values. This allows the system to determine whether the detected human presence poses a safety risk.

The **alert and mitigation unit** is responsible for generating immediate warnings when a hazardous condition is detected. It includes components such as a buzzer for audio alerts, an LED for visual indication, and a relay output for activating external alarm systems. Additionally, safety advisories such as warning signs can be triggered to inform individuals in the vicinity about potential danger.

The **IoT and monitoring unit** enables real-time communication and remote supervision. The ESP32's built-in Wi-Fi module transmits system data to a cloud server, such as Thing Speak or Firebase. This allows users to monitor system status through mobile or web-based dashboards. Alerts generated by the system are also sent to the user interface, ensuring timely awareness and response.

A regulated **5V DC power supply** is used to power the entire system, ensuring stable operation of all components. Additionally, local data storage using an SD card can be implemented for logging and analysis purposes. The overall architecture ensures efficient data flow from sensing to processing, followed by alert generation and remote monitoring, thereby providing a reliable and scalable safety solution for power transmission environments.

VI. HARDWARE & SOFTWARE COMPONENTS

Microwave radar sensor (RCWL-0516, detection range ~5–7 m, operating voltage 4–28 V),
ESP32 microcontroller (3.3 V logic, Wi-Fi 2.4 GHz),

Buzzer (5 V),

LED indicator (2–3 V with 330 Ω resistor),

Relay module (5 V, switching up to 230 V AC),

Regulated power supply (5 V DC) are used for sensing, processing, and alert generation.

Embedded programming using Arduino IDE (C/C++),

IoT cloud platforms such as Thing Speak/Firebase (real-time data logging and visualization),

Mobile/Web interfaces operating over Wi-Fi (2.4 GHz) are used for data processing, communication, and remote monitoring.

VII. METHODOLOGY

The proposed system adopts a systematic methodology to achieve real-time human detection and electrical hazard mitigation near power transmission lines. The overall process is organized into sequential stages, including sensing, signal processing, proximity evaluation, decision-making, alert generation, and IoT-based monitoring. Each stage is designed to ensure accurate detection and timely response under varying environmental conditions.

Initially, the **sensing stage** is carried out using a microwave radar sensor (RCWL-0516), which continuously emits electromagnetic waves into the surrounding environment. When a human enters the detection zone, the emitted waves are reflected back to the sensor. These reflections are captured as electrical signals, which vary based on motion and distance. This sensing approach is robust against environmental factors such as lighting variations, fog, and rain, making it suitable for outdoor deployment near power lines.

In the next stage, the acquired signals are transmitted to the **processing unit**, implemented using an ESP32 microcontroller. The microcontroller performs signal conditioning to filter noise and enhance signal clarity. It then executes motion detection algorithms to confirm the presence of a human target. Following detection, distance estimation techniques are applied to approximate the proximity of the detected object. These processing steps ensure reliable identification of potential hazards.

Subsequently, the system performs **proximity evaluation and hazard assessment** using predefined threshold values. The estimated distance is compared with a safety threshold determined based on permissible limits near high-voltage lines. If the detected object is outside the threshold range, the system continues monitoring without intervention. However, if the object is within the unsafe range, the system classifies the situation as hazardous.

Once a hazardous condition is identified, the **alert and mitigation stage** is activated. The system generates immediate warnings through a buzzer for audio alerts and an LED for visual indication. Additionally, a relay output can be used to trigger external safety devices such as alarms or warning systems. These mechanisms provide instant notification to individuals in the vicinity, helping to prevent accidental exposure to electrical hazards.

Simultaneously, the system leverages the **IoT communication stage** to transmit real-time data to a cloud server using the ESP32's built-in Wi-Fi module. The transmitted data includes detection status, proximity measurements, and alert conditions. This information is made accessible through mobile or web-based dashboards, enabling remote monitoring and quick response by authorized personnel.

Finally, the system operates in a continuous loop, ensuring uninterrupted monitoring and rapid response to dynamic environmental changes. The integration of sensing, processing, and communication modules provides a reliable and efficient methodology for enhancing safety near power transmission lines.

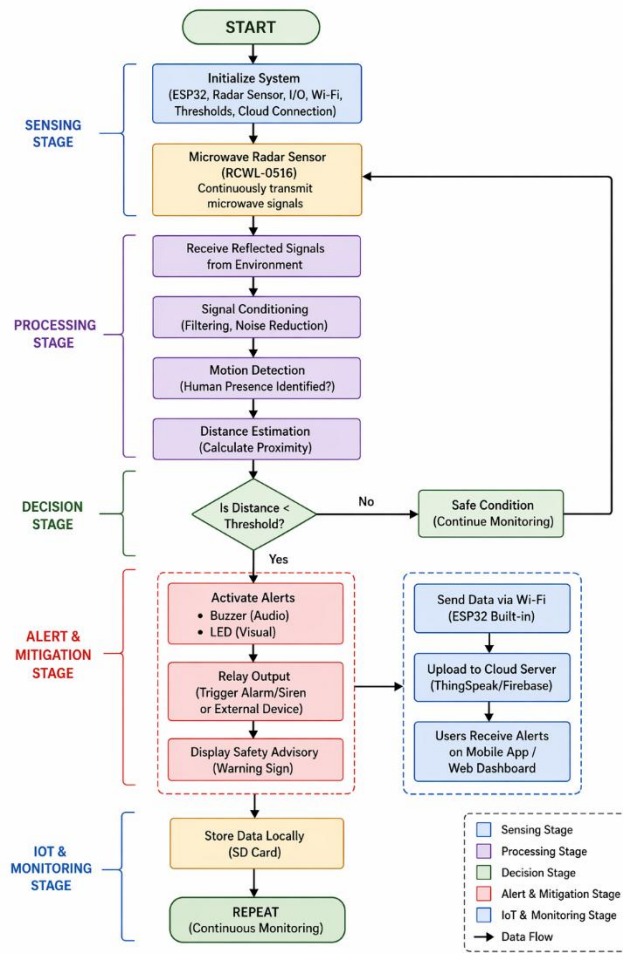

Figure 2: Flowchart of Step-By-Step Stage Process

VIII. SYSTEM WORKING

The proposed system operates through a sequence of coordinated stages to achieve real-time human detection and electrical hazard mitigation near power transmission lines. The process begins with the sensing unit, where the microwave radar sensor continuously emits electromagnetic waves into the surrounding environment. When a human enters the detection zone, the emitted waves are reflected back to the sensor. These reflected signals vary based on movement and proximity, enabling the detection of human presence irrespective of environmental conditions such as lighting, fog, or rain.

The reflected signals are then transmitted to the processing unit, which is implemented using an ESP32 microcontroller. In this stage, signal conditioning is performed to filter noise and improve the quality of the received data. The system then executes motion detection algorithms to confirm the presence of a human target. Following detection, distance estimation is carried out to determine the approximate proximity of the detected object relative to the power transmission line.

Once the distance is estimated, the system performs proximity evaluation and hazard assessment using predefined threshold values. The calculated distance is compared with a safety threshold to classify the situation. If the detected object is outside the safe boundary, the system continues normal monitoring. However, if the object is detected within the unsafe range, the system identifies it as a hazardous condition that requires immediate action.

Upon detection of a hazardous situation, the alert and mitigation unit is activated. The system generates immediate warnings through both audio and visual means. A buzzer provides an audible alert, while an LED indicator offers visual notification. Additionally, a relay output can be used to activate external alarm systems or safety devices. Warning signs or advisory signals can also be triggered to inform individuals about the potential danger.

Simultaneously, the system utilizes the IoT monitoring unit for real-time communication. The ESP32's built-in Wi-Fi module transmits the processed data, including detection status and hazard level, to a cloud server. This information is made accessible through mobile or web-based dashboards, allowing users to monitor the system remotely. Alerts are also sent to the user interface to ensure immediate awareness and response.

The entire system operates in a continuous loop, ensuring uninterrupted monitoring and rapid response to dynamic changes in the environment. By integrating sensing, processing, alerting, and communication functions, the system provides an efficient and reliable solution for enhancing safety near power transmission lines.

XI. RESULTS AND DISCUSSION

The comparative results presented in Table 1 provide a comprehensive evaluation of the proposed system against the existing system in terms of detection accuracy and response time across varying distances. It is evident that the proposed system consistently outperforms the conventional approach, maintaining superior accuracy and significantly reduced response time throughout the tested range.

Table 1: Comparative analysis of detection accuracy and response time between existing and proposed systems at different distances

<i>Distance (m)</i>	<i>Existing System Accuracy (%)</i>	<i>Proposed System Accuracy (%)</i>	<i>Existing System Response Time (s)</i>	<i>Proposed System Response Time (s)</i>
1	85	98	2.5	1.1
2	83	97	2.6	1.2
3	80	96	2.7	1.3
4	78	94	2.8	1.4
5	75	92	3.0	1.5
6	72	89	3.2	1.6
7	68	85	3.5	1.8
8	65	80	3.8	2.0

As the distance increases from 1 m to 8 m, both systems exhibit a gradual decline in detection accuracy; however, the rate of degradation differs considerably. The existing system shows a sharp reduction in accuracy, decreasing from 85% to 65%, which can be attributed to its reliance on infrared or vision-based sensing techniques that are highly sensitive to environmental disturbances and signal attenuation. In contrast, the proposed system demonstrates a more stable performance, with accuracy decreasing from 98% to 80%. This comparatively slower degradation indicates the robustness of microwave radar sensing, which effectively detects motion and presence through electromagnetic wave reflection, even at extended distances.

The response time analysis further highlights the efficiency of the proposed system. The existing system exhibits a relatively higher and increasing response time, ranging from 2.5 s to 3.8 s as the distance increases. This delay is primarily due to limitations in sensing mechanisms and processing overhead associated with conventional technologies. On the other hand, the proposed system maintains a significantly lower response time, ranging from 1.1 s to 2.0 s. The reduced latency can be attributed to the efficient signal processing capabilities of the ESP32 microcontroller and the use of a threshold-based decision algorithm, which minimizes computational complexity and enables rapid hazard evaluation.

Another important observation is the consistency of the proposed system under varying conditions. The use of microwave radar ensures reliable operation irrespective of environmental factors such as lighting variations, fog, or rain, which typically degrade the performance of existing systems. This environmental independence contributes to both higher accuracy and faster response, making the proposed system more suitable for outdoor deployment in power transmission environments.

Furthermore, the integration of IoT communication enhances the system's effectiveness by enabling real-time data transmission and remote monitoring. Although this feature is not directly reflected in the numerical results, it significantly improves the practical usability of the system by allowing immediate alert dissemination and centralized supervision.

Overall, the results validate that the proposed system provides a substantial improvement over existing methods in terms of accuracy, responsiveness, and operational reliability. The combination of microwave radar sensing, efficient embedded processing, and IoT connectivity establishes a robust framework for real-time human detection and electrical hazard mitigation, making it highly suitable for safety-critical applications near power transmission lines.

CONCLUSION

The proposed system presents an effective solution for human detection and electrical hazard mitigation near power transmission lines using IoT-integrated microwave radar. It achieves higher detection accuracy and faster response time compared to conventional methods, while maintaining reliable performance under varying environmental conditions. The integration of embedded processing and IoT communication enables real-time monitoring and timely alert generation. Overall, the system offers a cost-effective, scalable, and efficient approach to improving safety in power transmission environments.

FUTURE SCOPE

The proposed system can be further improved by integrating machine learning algorithms to enable predictive hazard detection and reduce false alarms. The inclusion of additional sensors such as thermal or ultrasonic sensors can enhance accuracy, particularly for stationary object detection. Future work may also focus on deploying multiple interconnected units to provide wide-area coverage along power transmission lines. Integration with smart grid systems and advanced communication technologies like 5G can improve real-time monitoring and response. Additionally, the use of low-power designs and renewable energy sources can support deployment in remote locations, making the system more efficient and scalable.

REFERENCES

- [1] Kozak R., Wiltshire B. D., Khandoker M. A. R., Golovin K. and Zarifi M. H. 2020. Modified microwave sensor with a patterned ground heater for detection and prevention of ice accumulation. *ACS Applied Materials & Interfaces*. 12(49): 55483-55492. J. Clerk Maxwell, *A Treatise on Electricity and Magnetism*, 3rd ed., vol. 2. Oxford: Clarendon, 1892, pp.68–73.
- [2] Rafi Vempalle and P. K. Dhal. 2020. Loss Minimization by Reconfiguration along with Distributed Generator Placement at Radial Distribution System with Hybrid Optimization Techniques. *Technology and Economics of Smart Grids and Sustainable Energy*. Vol. 5..
- [3] IEEE Power & Energy Society. (2018). "Transmission Line Fault Detection and Location Using Internet of Things (IoT) Sensors: A Case Study." *IEEE Transactions on Power Delivery*, 33(2), 905-914.
- [4] Rafi Vempalle and P. K. Dhal. 2020. Maximization savings in distribution networks with optimal location of type-I distributed reconfiguration using generator PSO-DA along with optimization techniques. *Materials Today: Proceedings*. 33: 40944100.
- [5] International Conference on Power System Technology. (2019). "Smart Sensors for RealTime Transmission Line Fault Detection." *Proceedings of the 13th International Conference on Power System Technology*, 1-6.