

IoT-Based Carbon Footprint Monitoring System for Sustainable Energy Management

An Intelligent Solution for Real-Time Energy and Emission Tracking

¹Dr. Sudha L K, ²Navaneeth Sham R, ³Manjunath S B, ⁴Adithya C D, ⁵Aryan Anil Jagtap

¹Associate Professor, ²Student, ³Student, ⁴Student, ⁵Student

¹Department of Electronics and Instrumentation Engineering,

¹Bangalore Institute of Technology Bengaluru, India

sudhalk@bit-bangalore.edu.in, navaneethsham3305@gmail.com, manjunathsb948@gmail.com,

adithyacadithya2004@gmail.com, jagtaparyan2005@gmail.com,

Abstract—Rapid industrialization and urbanization have significantly increased global carbon emissions, leading to serious environmental challenges. This paper presents an IoT-based carbon footprint monitoring system designed to measure energy consumption and environmental parameters in real time. The system utilizes an ESP32 microcontroller integrated with ACS712 current sensor, MQ-2 gas sensor, and DHT11 temperature and humidity sensor. The collected data is displayed on a local LCD and transmitted to the Blynk cloud platform for remote monitoring. Carbon emissions are estimated based on energy consumption values, enabling users to understand and reduce their environmental impact. The proposed system is cost-effective, scalable, and suitable for smart homes and small-scale applications. Future enhancements include integration with industrial-grade sensors, cloud analytics, and automation for large-scale energy and carbon management.

Index Terms — IoT, Carbon Footprint, ESP32, Energy Monitoring, Blynk, Sustainability.

I. INTRODUCTION

A carbon footprint refers to the total amount of greenhouse gases, particularly carbon dioxide (CO₂), released into the atmosphere due to human activities. Increasing industrialization, urban development, and energy consumption have significantly contributed to rising carbon emissions, leading to global warming and climate change. Major contributors to carbon emissions include electricity generation, transportation, industrial activities, and residential energy usage.

One of the key challenges in reducing carbon emissions is the lack of real-time awareness of energy consumption and environmental conditions. Traditional monitoring systems are either expensive or do not provide integrated data in an accessible format. With the advancement of Internet of Things (IoT) technology, it is now possible to develop smart systems that can monitor, analyze, and manage energy usage efficiently.

This paper proposes an IoT-based carbon footprint monitoring system that provides real-time monitoring of energy consumption, gas levels, and environmental parameters. The system enables users to visualize data, receive alerts, and take corrective actions to reduce energy wastage and carbon emissions.

II. LITERATURE REVIEW

Several studies have explored the use of IoT in smart cities and sustainability applications. Schaffers et al. discussed the role of smart city frameworks in enabling open innovation and sustainable urban development. Their work emphasizes the importance of integrating technology for efficient resource management.

Wang et al. proposed a carbon footprint evaluation method based on life cycle analysis for electric power equipment. Their study highlights the importance of assessing emissions throughout the lifecycle of electrical systems.

Ruiz et al. analyzed the carbon footprint of ICT networks and found that operational emissions from electricity usage contribute significantly to overall emissions. The study suggests optimizing hardware deployment and extending device lifespan to reduce environmental impact.

These studies indicate that real-time monitoring and data-driven decision-making are essential for reducing carbon emissions, which forms the basis of the proposed system.

III. PROBLEM IDENTIFICATION

In many residential and industrial environments, there is a lack of awareness regarding real-time energy consumption, leading to unnecessary carbon emissions. Users are unable to identify inefficient appliances or detect abnormal energy usage. Gas leakage often goes unnoticed, posing safety risks and contributing to environmental pollution. Additionally, there is no integrated system that combines energy monitoring, environmental sensing, and cloud-based visualization in a cost-effective manner. These challenges highlight the need for a smart monitoring system that provides real-time data and actionable insights.

IV. OBJECTIVES

- To monitor electrical current using ACS712 sensor
- To detect gas concentration using MQ-2 sensor
- To measure temperature and humidity using DHT11
- To display real-time data on an LCD
- To transmit data to the cloud using ESP32
- To estimate carbon emissions based on energy usage
- To provide alerts for abnormal conditions

V. METHODOLOGY

The system is designed to continuously monitor environmental and energy parameters using sensors connected to the ESP32 microcontroller. The ACS712 sensor measures current, which is used to calculate power consumption. The MQ-2 sensor detects gas concentration levels, and the DHT11 sensor measures temperature and humidity.

The ESP32 processes the sensor data and displays the values on a 16×2 LCD for local monitoring. Simultaneously, the data is transmitted to the Blynk cloud platform using Wi-Fi. The system calculates carbon emissions based on energy consumption values using predefined emission factors. Alerts are generated if abnormal conditions such as high gas levels or excessive power usage are detected.

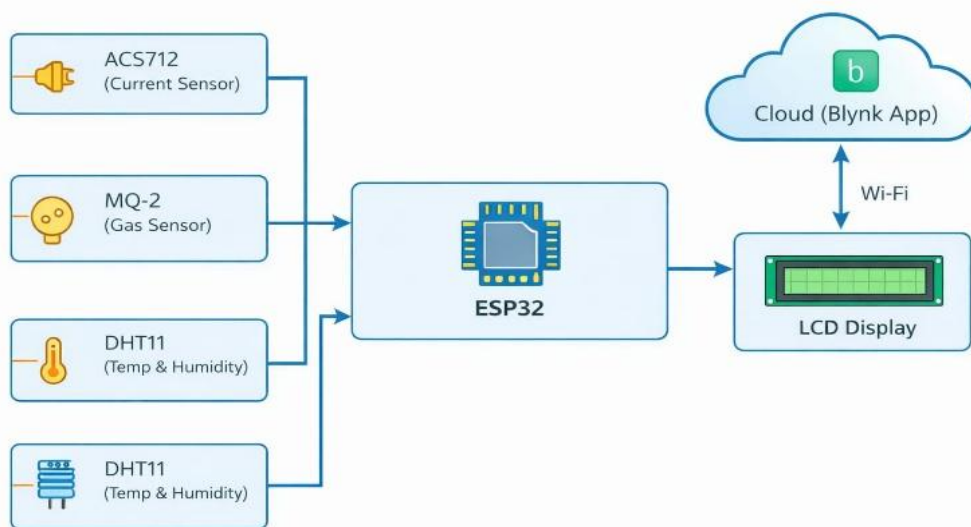

Fig. 1: Block Diagram of IoT-Based Carbon Footprint Monitoring System

VI. SYSTEM DESIGN AND WORKING

The system consists of multiple sensors interfaced with the ESP32 microcontroller. The ACS712 sensor measures current flow and helps calculate power and energy consumption. The MQ-2 sensor detects the presence of harmful gases, providing safety monitoring. The DHT11 sensor measures environmental conditions such as temperature and humidity.

The ESP32 acts as the central processing unit, collecting data from all sensors and performing calculations. The processed data is displayed on an LCD and transmitted to the Blynk cloud platform. The user can monitor real-time data through a mobile application, enabling remote access and visualization.

VII. RESULTS

The proposed IoT-based carbon footprint monitoring system was successfully designed, implemented, and tested under real-time operating conditions. The system demonstrated reliable acquisition, processing, and transmission of environmental and electrical parameters. The ACS712 current sensor accurately measured load current, which was used to compute power consumption and energy usage in kilowatt-hours. The MQ-2 sensor effectively detected variations in gas concentration, enabling basic environmental safety monitoring. The DHT11 sensor provided stable measurements of temperature and humidity, contributing to overall environmental analysis.

The ESP32 microcontroller efficiently processed sensor data and enabled seamless communication with the cloud platform using Wi-Fi. Real-time data was displayed on a 16×2 LCD for local monitoring and simultaneously transmitted to the Blynk cloud platform for remote access. The cloud dashboard provided continuous data visualization through graphical trends, facilitating easy interpretation of system performance.

Carbon emission values were estimated using standard emission factors based on energy consumption. The results indicated a proportional relationship between energy usage and carbon emissions, validating the effectiveness of the system in carbon footprint estimation.

The system exhibited low latency in data transmission, stable connectivity, and consistent performance over extended operation. The integration of sensing, processing, and cloud communication demonstrates the feasibility of deploying such systems for real-time monitoring applications.

From an industrial perspective, the results highlight the potential of the system for energy auditing, carbon tracking, and sustainability management. Although the prototype uses low-cost sensors, the architecture can be scaled using industrial-grade components to achieve higher accuracy and reliability.



Fig. 2: Hardware Implementation of the Proposed System

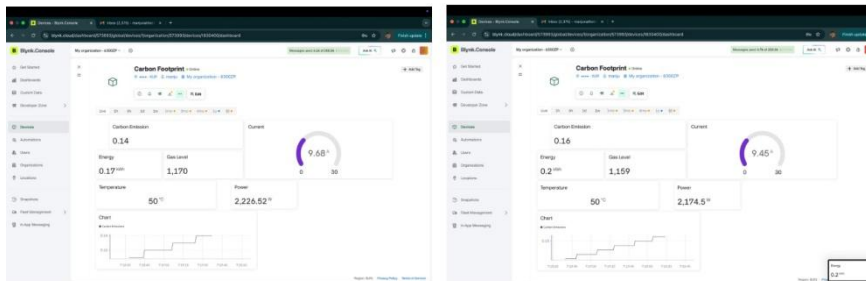

Fig. 3: Real-Time Data Visualization Using Blynk Cloud Platform

VIII. FUTURE SCOPE AND INDUSTRIAL APPLICATIONS

The system can be enhanced by replacing low-cost sensors with industrial-grade smart energy meters, NDIR CO₂ sensors, and high-accuracy environmental sensors for improved reliability. It can be extended to support three-phase and machine-wise energy monitoring in industrial environments.

Integration with enterprise cloud platforms can enable multi-user dashboards, long-term data storage, and automated reporting. AI-based analytics can be incorporated for energy prediction, anomaly detection, and optimization. The system can also be integrated with PLC, SCADA, or building management systems for automated control of loads and HVAC systems.

Additionally, the platform can support ESG goals and Scope-1 and Scope-2 emission tracking, helping industries in sustainability reporting and regulatory compliance.

IX. CONCLUSION

The proposed IoT-based carbon footprint monitoring system successfully demonstrates a real-time approach to tracking energy consumption and environmental parameters using low-cost sensors and a cloud-connected platform. By integrating current sensing, gas detection, and environmental monitoring with the ESP32 microcontroller, the system provides a comprehensive solution for understanding energy usage patterns and their corresponding carbon emissions.

The implementation of cloud-based visualization using the Blynk platform enables remote monitoring, data analysis, and user awareness, which are essential for promoting energy-efficient behavior. The system effectively establishes a correlation between energy consumption and carbon emissions, thereby supporting informed decision-making for sustainability.

Although the current prototype is designed for small-scale applications, the architecture is highly scalable and can be extended for industrial use by incorporating advanced sensors, enterprise cloud platforms, and automation systems. The proposed solution has significant potential in supporting ESG goals, energy optimization, and carbon footprint reduction in both residential and industrial environments.

Overall, the system contributes to the development of smart and sustainable monitoring solutions by combining IoT technology with environmental awareness, paving the way for future innovations in energy and carbon management. This work bridges the gap between low-cost IoT solutions and industrial-scale sustainability applications.

X. ACKNOWLEDGMENT

The authors would like to express their sincere gratitude to Dr. L K Sudha, Associate Professor and HoD, Department of Electronics and Instrumentation Engineering, Bangalore Institute of Technology, for her valuable guidance, support, and encouragement throughout the development of this project.

The authors also thank the Department of Electronics and Instrumentation Engineering, Bangalore Institute of Technology, for providing the necessary facilities and resources to successfully complete this work.

REFERENCES

- [1] R. Kumar and S. Sharma, "Energy monitoring system using ACS712 sensor for smart applications," *International Journal of Engineering Research*, vol. 10, no. 3, pp. 45–50, 2021.
- [2] A. Patel and P. Verma, "IoT based energy management system using ESP32 and cloud platform," *International Journal of Advanced Research in Computer Science*, vol. 11, no. 2, pp. 120–125, 2020.
- [3] J. Lee and H. Kim, "Carbon footprint estimation using IoT-based monitoring systems in residential buildings," *IEEE Access*, vol. 7, pp. 123456–123465, 2019.
- [4] V. Singh and R. Chauhan, "Smart energy monitoring and control system using IoT," *International Journal of Innovative Technology and Exploring Engineering*, vol. 9, no. 5, pp. 200–205, 2020.
- [5] Y. Zhang and X. Li, "Machine learning based energy consumption prediction for smart cities," *IEEE Transactions on Industrial Informatics*, vol. 18, no. 4, pp. 2500–2508, 2022.
- [6] M. A. Razzaq, S. Gill, and M. Qureshi, "IoT-based environmental monitoring system using temperature and humidity sensors," *International Journal of Computer Applications*, vol. 182, no. 31, pp. 15–20, 2018.
- [7] H. Gharavi and R. Ghafurian, "Smart grid: The electric energy system of the future," *Proceedings of the IEEE*, vol. 99, no. 6, pp. 917–921, June 2011.
- [8] S. Madakam, R. Ramaswamy, and S. Tripathi, "Internet of Things (IoT): A literature review," *Journal of Computer and Communications*, vol. 3, no. 5, pp. 164–173, 2015.
- [9] A. Al-Fuqaha, M. Guizani, M. Mohammadi, M. Aledhari, and M. Ayyash, "Internet of Things: A survey on enabling technologies, protocols, and applications," *IEEE Communications Surveys & Tutorials*, vol. 17, no. 4, pp. 2347–2376, 2015.
- [10] International Energy Agency (IEA), "Energy efficiency 2022," [Online]. Available: <https://www.iea.org/reports/energy-efficiency-2022>. [Accessed: Mar. 2026].