

# Super capacitor Buffered V2V Energy Sharing for Ripple-Free Mobile EV Charging

1<sup>st</sup> Kishore Kumar Golla, 2<sup>nd</sup> Venkatesh Gadi, 3<sup>rd</sup> Ashok Sarella

<sup>1</sup>B.tech, Dept of E.E.E, NITS, Miryalguda, TS, <sup>2</sup>B. Tech, Dept of E.E.E, Kakinada Institute of Engineering and Technology -Korangi, AP <sup>3</sup>B. Tech, Dept of E.E.E, BVCIT ,Batlapalem -Amalapuram, AP

[KishoreKumarg22@gmail.com](mailto:KishoreKumarg22@gmail.com), <sup>2</sup> [venkatesh.gadi21.com](mailto:venkatesh.gadi21.com),  
<sup>3</sup>[ashoksarella@gmail.com](mailto:ashoksarella@gmail.com)

## Abstract:

Direct energy exchange between batteries causes significant current ripple, transient instability, and thermal stress on lithium-ion packs; yet, vehicle-to-vehicle (V2V) power transfer is becoming a mobile charging method for grid-independent assistance. In response to these shortcomings, the authors provide a Supercapacitor-Assisted V2V Bidirectional Charging Architecture, in which a bank of supercapacitors works in tandem with the battery to provide a fast-dynamic power buffer. A real-time current-sharing controller distributes transient power demand to the supercapacitor, decreasing strain on the battery during acceleration and rapid changes in load, while a bidirectional DC-DC converter facilitates regulated energy exchange. The findings from MATLAB/Simulink show that, in comparison to traditional V2V charging, the suggested method improves transient reaction speed from 4s to 7s, lowers thermal increase by about 74%, and reduces ripple current by 70-82%. Hybrid energy storage models are ideal for next-gen vehicle-to-grid (V2G) charging networks and mobile recharging systems that run on highways because they enhance charge distribution, extend battery life, and provide reliable energy transmission between moving EVs.

## 1. INTRODUCTION

Many recall electric powered cars (EVs) to be an vital tool in the fight against transportation-related pollutants. Also, the share of EVs is growing at an exponential charge because of worldwide applications that promote the use of EVs. A huge challenge is the need to frequently recharge electric motors even as driving because of their confined range. Additionally, the expensive fee and limited battery lifestyles that include EV utilization is a huge trouble. Hence, a number of research goes into the use of renewable

power to electricity sufficient electric automobile charging stations. Powering EV charging stations on this area are renewable energy resources inclusive of gasoline mobile stacks, wind generators, and solar photovoltaic arrays.

As a end result, assembly the power demand at the same time as also improving environmental situations calls for a hybrid technique that balances the unpredictability of each allotted energy deliver. Charging EVs with the right manipulate algorithms is also a main situation right now.

In addition, a European Union observe determined that the transportation sector changed into responsible for round 28% of total emissions and that road site visitors accounted for more than 70% of CO<sub>2</sub> emissions in the transportation vicinity. Authorities in the general public of industrialised countries are selling the usage of EVs as a way to reduce emissions of CO<sub>2</sub> and other ozone-depleting pollution. In specific, they push for environmentally pleasant and green transportation by means of various tasks, such as tax reduction, purchase appropriations, or other interesting arrangements, such free open stopping or toll road utilisation. Compared to standard vehicles, electric vehicles provide numerous benefits:

- Vehicles that use these fuels do not contribute to atmospheric concentrations of carbon dioxide (CO<sub>2</sub>) or nitrogen dioxide (NO<sub>2</sub>). Even while creating batteries has an adverse influence on carbon footprint, the production processes are often beneficial for the environment.
- Electric vehicle (EV) engines are simpler and need fewer moving components, resulting in lower repair costs. Because they do not need a cooling circuit, gearshift, clutch, or noise-reduction components, the engines are compact, simple, and noiseless.
- Dependability: With fewer and simpler parts, this kind of vehicle has fewer breakdowns. Vibrations, petrol corrosion, explosions, and engine wear and tear are also not a problem for electric cars.

- Compared to conventional gas-powered cars, which incur far greater maintenance and fuel expenses, electric vehicles offer much lower support and power costs. There is a significant difference in the energy cost per km of electric cars and conventional automobiles.
- A more comfortable alternative is riding in an electric car since there are no vibrations or engine sounds.

In order to alleviate concerns about running out of juice, V2V charging enables electric vehicle owners to pool their energy resources with one another at minimal cost and with no infrastructure. First, there are the communication components of vehicle-to-grid (V2G) energy sharing, which allow electric vehicle (EV) users to connect with one another and determine who will provide and who will receive energy, as well as the rate for both parties. The methods for matching the receiver EV, provider EV, closest meeting place, and V2V communication elements are given in [7]-[10] and are based on game theory. The second critical component of vehicle-to-vertical (V2V) communication is the power interface, which regulates the flow of power according to the preferences of both the supplier and the receiver, and converts it to buck or boost according to the voltage of the electric vehicle's battery. One of the fundamental V2V methods described in [11] and [12] involves connecting to the alternating current (ac) power grid using off-board bidirectional power converters to achieve an indirect V2V energy transfer; nevertheless, this technique has poor conversion efficiency because of the many redundant conversion steps.

According to [13], there is a potential for an off-board V2V charger that uses an off-board bidirectional interleaved dc-dc converter to connect to the grid. Both [14] and [15] include methods for V2V charging that use an off-board power interface. Also, you may split the power bill between two electric vehicles with an Andromeda Power 50 kW off-board V2V charger [16], [17]. However, buyers of electric vehicles may have to shell out more cash and find more room in their vehicles for an external V2V interface if they choose for this off-board V2V method. In contrast, methods for vehicle-to-vehicle (V2V) communication that make use of the vehicle's type-1 and type-2 chargers as power interfaces are detailed in references [18] and [19]. An active rectifier stage and a dc-dc converter [for constant current and constant voltage (CCCV) charge regulation] make up the onboard type-1 and type-2 chargers essentially.

As illustrated in Figure 1.1(a), a V2V charging method is shown by linking the type-1 charger input ports of the two electric vehicles. The provider EV battery's direct current output is first transformed into single-phase alternating current (ac) by means of the bidirectional two-stage type-1 ac charger that is installed on-board.

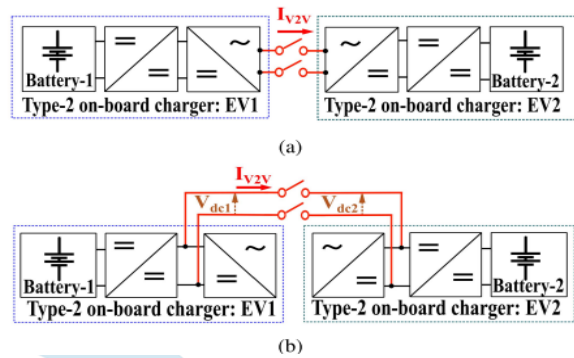

Fig 1.1 V2V operations: (a) ac V2V operation and (b) dc V2V operation.

The -degree on-board kind-1 converter takes this alternating current (ac) power output from the provider EV and uses it to charge the battery of the receiving EV. The efficiency of V2V charging is decreased because of cascading converter losses caused by redundant conversion steps, as stated in [18]. V2V charging is shown in [19] as seen in Fig. 1.1(b) by way of directly connecting the dc-hyperlink of the 2 EVs using mechanical switches. However, in practice, the dc-hyperlink of battery aspect dc-dc converters can not be directly accessed to be able to obtain the direct connection this is defined. Accordingly, the V2V approach given in [19] is impractical because it requires tailor-made layout changes and additional charging ports to extract the dc-hyperlink terminals from the two EVs. In order to price electric powered cars the usage of voltage-to-contemporary (V2V) technology, this newsletter suggests connecting the on-board type-2 strength consumption ports without delay to the chargers. This technique does away with the want for additional ports or other equipment. Additionally, to shorten the V2V strength switch path, the advised approach uses the energetic rectifier ranges as a connecting interface to hyperlink EV batteries. The efficiency is substantially improved through lowering the variety of conversion steps, which in turn reduces the wide variety of energetic switches that make a contribution to switching and conduction losses. The cautioned vehicle-to-grid (V2G) technique includes mode choice good judgment that determines whether or not the EV have to perform in greenback or improve mode depending on the user's preference and the modern-day and voltage degrees in the battery. Regardless of the disparity inside the voltage scores of the 2 EV batteries, the ability to govern the drift of energy in both way offers EV users extra freedom to behave as both providers or receivers. In assessment to previous techniques, the counseled approach of connecting the 2 EV batteries thru on-board energetic

rectifier switches eliminates the need for an off-board V2V interface, redundant strength switch stages, associated losses, and additional contactor switches. This improves the general efficiency of the V2V machine.

## ELECTRICAL VEHICLES

In terms of both financial outcome and investment in research and development, the automotive industry has grown into a global powerhouse. More and more modern vehicles include safety features designed to make pedestrians and drivers alike feel more at ease on the road. Also, with more cars on the road, we can travel more comfortably and quickly.

Carbon monoxide (CO), particulate matter (PM), sulphur dioxide (SO<sub>2</sub>), and nitrogen oxides (NO<sub>x</sub>) have all tragically increased in concentrations due to this in urban areas. The region accounts for around 28% of total emissions, while street mobility is responsible for over 70% of transportation-related CO<sub>2</sub> emissions, according to an EU study.

Governments in most developed countries are encouraging the purchase of electric vehicles as a means to reduce emissions of carbon dioxide and other greenhouse gases. Specifically, they push for transport policies that are both economical and kind to the environment via a range of initiatives, most often including subsidies for purchases or tax cuts, but often include more novel ideas like free public parking or highway use. When compared to gas-powered automobiles, electric vehicles offer several advantages:

- Zero emissions: these cars don't let out any harmful gases like carbon dioxide (CO<sub>2</sub>) or nitrogen dioxide (NO<sub>2</sub>). In general, the production methods are better for the environment, even if creating batteries has a negative impact on carbon footprint.
- Electric vehicle (EV) motors need much less maintenance due to their reduced complexity. Without a cooling circuit, gearshift, grip, or noise reduction components, the motors are smaller, simpler, and quieter.
- Having fewer and simpler components increases the dependability of this kind of vehicle, leading to fewer breakdowns. → Vibrations, petrol corrosion, explosions, and engine wear and tear are also not a problem for electric cars.
- Electric vehicles have much lower maintenance and energy costs compared to traditional gas-powered vehicles. → Electric vehicles have a far lower energy cost per km than gas-powered vehicles, as seen in Figure.

- Since there are no vibrations or engine sounds while travelling in an electric car, it is more enjoyable than in a regular vehicle. In terms of efficiency, electric vehicles are head and shoulders above the competition.
- Another element that will decide the well-to-wheel (WTW) ratio is the overall efficiency of the power plant. In terms of total WTW efficiency, diesel vehicles may achieve values between 25% and 37%, whereas petrol vehicles can achieve values between 11% and 27%. Compared to EVs driven by natural gas power plants, which have a WTW efficiency of 13% to 31%, EVs powered by renewable energy sources may reach an overall efficiency of 70%.
- This sort of vehicle may be able to enter some urban areas, such as low emissions zones, where other combustion automobiles are not allowed. Electric vehicles are exempt from some traffic regulations in large cities, even during the peak pollution hours. Worse still, recent OECD study shows that EVs won't assist with the air quality issue, at least not with PM emissions.

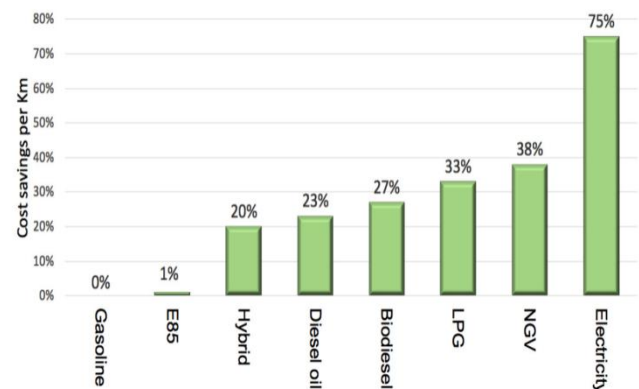

**Figure 1.** Comparison of savings in cost per kilometer offered by vehicles powered by Gasoline, Ethanol (E85), Hybrid, Diesel oil,

## 3. MODELLING OF CASE STUDY

### 3.1 PROPOSED V2V APPROACH

The suggested vehicle-to-vehicle (V2V) setup is made possible by linking the two EVs' current type-2 charging connections. Using the three-phase active rectifier switches, the two EVs are linked. Directly connecting the two EV batteries through the intermediate dc-link of the provider and receiver EVs is achieved by turning ON the top switch of one of the phases (phase-a, S<sub>1</sub> here) and the bottom switch of the other phase (phase-c, S<sub>6</sub> here) of the active rectifier-1, as well as the corresponding phase switches S'<sub>1</sub> and S'<sub>6</sub> of the active rectifier-2, as illustrated in Figure 4.1. No power is transferred between the four switches S<sub>1</sub>, S<sub>6</sub>, S'<sub>1</sub>, and S'<sub>6</sub> during the V2V power transfer. The suggested method of linking the two EVs makes use of a dual

bidirectional buck-boost converter, which can be adjusted to conduct energy transfers in either direction between the two EVs, independent of the voltage levels of their batteries. For the duration of the V2V operation, the other switches on both active rectifiers are deactivated as they are not really rectified but rather serve as an interface for connecting two dc-links. Depending on the voltage of two electric vehicles' batteries, the setup might use one of the energy transfer mechanisms described below.

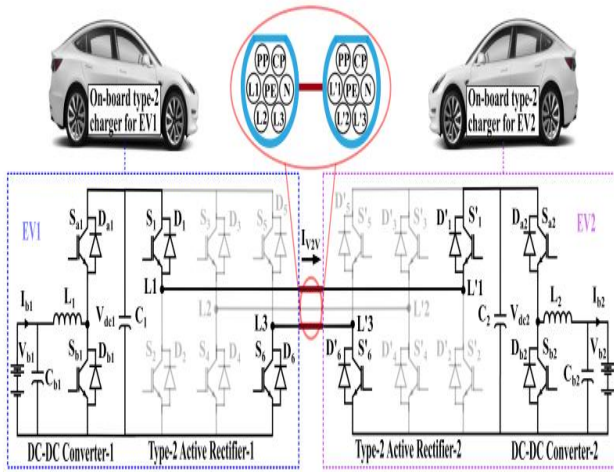

Fig. 3.1 Proposed topology for V2V operation.

### 3.2 CONTROL SCHEME FOR THE PROPOSED V2V APPROACH

In the proposed V2V method, the on-board converters regulate the charging rate and the total energy delivered. Figure 6 shows the mode selection flow that uses the provider receiver information and the EV-1 and EV-2 battery numbers to decide on the V2V mode. In order to achieve the intended V2V, the on-board charger converters are regulated according to the mode of operation, as previously mentioned.

#### 3.2.1 Control of the Active Rectifiers as V2V Interface

The active rectifier is usually operated in d-q control mode to convert three-phase ac to dc with unity power factor at the grid terminals during regular three-phase ac charging with a type-2 charger. The active rectifier is repurposed as a connector to access and link the two EVs' batteries during the planned V2V charging. During all modes of V2V charging, once the type-2 charger ports have been connected, the gating pulse for the active rectifier-1 switches S1 and S6 and the active rectifier-2 switches S'1 and S'6 remains high. This applies to both the EV-1 and the active rectifier-2.

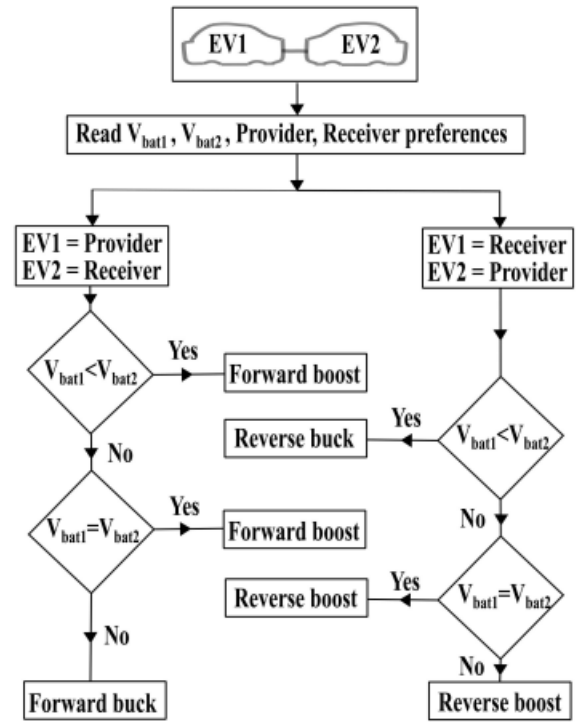

Fig. 3.2 Proposed V2V power transfer control flow.

#### 3.2.2 Control of DC-DC Converters.

##### Method for Regulation

The calculation of the reference current is then divided between the SC and the Li-ion battery. Instantaneous reaction from the supercapacitor improves transient responsiveness and reduces dip/ripple.

Efficient energy sharing between EVs, rapid dynamic recovery, and ripple-free current transmission are the control objectives of the proposed V2V system. In the suggested concept, the supercapacitor (SC) functions as a high-power buffer, providing peak current during transient disturbances, in contrast to traditional V2V systems that rely only on batteries to give low-frequency stable power. A control architecture with many layers is implemented, which includes:

##### Reference Voltage & Current Formulation

The main regulation target is to maintain DC-link voltage  $V_{dc}$  within safe tolerance under dynamic load and source variations.

$$v = V_{dcref} - V_{dce\_v} = V_{dc}^{ref} - V_{dc}$$

A PI regulator generates reference inductor current:

$$I_{ref}$$

## 5. simulation results

Simulation model

### Extension:

A controlled continuous flow is maintained by the Li-ion battery, and the SC facilitates energy transmission during rapid changes in load. Power stability and protection against severe discharge stress are both enhanced by this hybrid energy storage system.

#### Without integration of sc of v2v

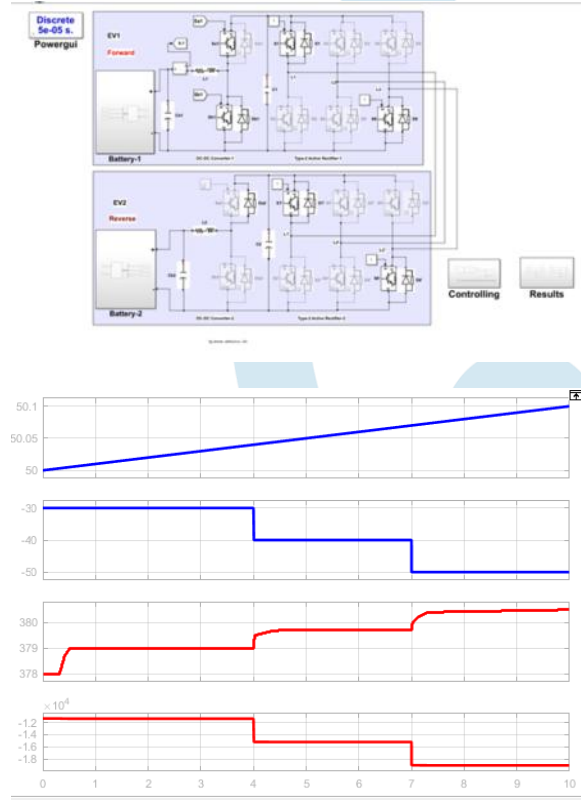

Fig shows EV1 state of charge, EV1 battery current, EV1 battery voltage, EV1 battery power

Fig Simulation results of the proposed V2V operation in the without SC (a) SOC, voltage, current, and power waveforms of EV-1 battery. (b) SOC, voltage, current of EV-2 battery, and dc-link voltage.

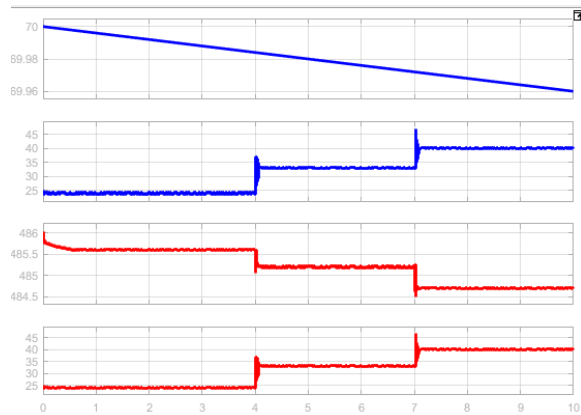

Fig shows EV2 state of charge, EV2 battery current, EV2 battery voltage, EV2 battery power

The energy exchange method in the first V2V arrangement is limited to Li-ion batteries alone. The Li-ion battery must provide both steady-state and peak transient power during sudden changes in the load. The electric vehicle battery ages more quickly and experiences thermal stress as a consequence of the observable variations in current and dc-link power.

Variation in state-of-charge (SOC), battery current and voltage, and power response are some of the performance parameters shown in Fig. during power transfer. With each energy delivery from EV-1 to EV-2, the SOC drops a little bit. When the load demand fluctuates quickly, the battery current and power waveforms show abrupt power peaks, suggesting less stability.

Similarly, EV-2's SOC, voltage, current, and dc-link voltage are shown in Fig. Although the receiving vehicle's SOC increases in tandem, ripple and temporary variations are caused by the lack of a high-power buffer. It is evident that depending just on Li-ion batteries for V2V operation in dynamic environments has its limits.

### Observation:

Without the use of supercapacitors, Li-ion batteries experience voltage ripples, peak current spikes, and decreased efficiency during voltage-to-voltage (V2V) transfer due to direct transient load stress.

### B. Integration super capacitor with series resistor

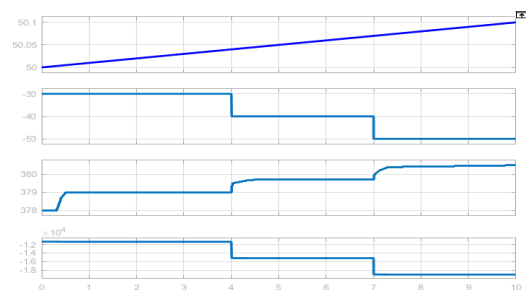
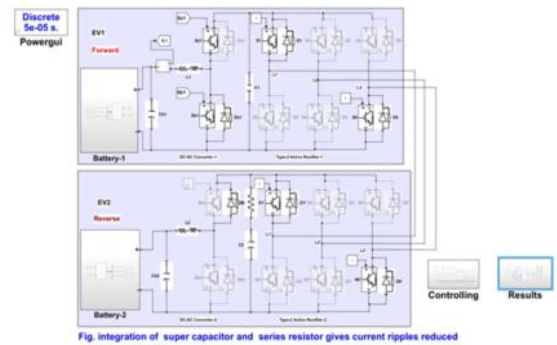

Fig shows EV1 state of charge, EV1 battery current, EV1 battery voltage, EV1 battery power

Power, voltage, current, and state-of-charge (SOC) waveforms for the EV-1 battery, as simulated in conjunction with the planned V2V operation. (b) dc-link voltage, state of charge, voltage, and current carried by the EV-2 battery.

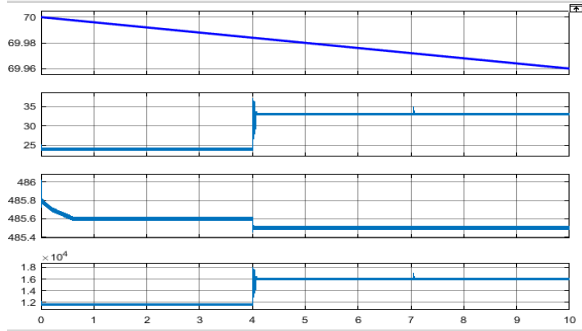

Fig shows EV2 state of charge, EV2 battery current, EV2 battery voltage, EV2 battery power

**V2V Operation With Integrated Supercapacitor (SC + R Series Damping)**

A bank of supercapacitors and a dampening resistor are connected in series and interfaced with the DC bus to improve the system's responsiveness. The SC adjusts to sudden fluctuations in load, while the Li-ion battery keeps up with the constant, steady energy demand.

Figure Y(a) displays the EV-1 parameters after the integration of SC. Voltage stays more consistent throughout the transfer duration, SOC lowers slowly with regulated discharge slope, and battery current peaks are greatly minimised. Instead of the battery delivering abrupt current pulses, the supercapacitor can handle these short bursts of surges.

The reaction of the EV-2 with SC assistance is seen in Figure Y(b). Dc-link voltage stays well-regulated, and SOC rises as ripple decreases. In order to improve conversion efficiency and decrease heat strain on the battery, the coordinated hybrid energy storage actively ensures smooth power exchange.

The benefits of a supercapacitor include less thermal stress, a longer lifetime for the battery, smooth power flow, and immediate power support.

Parameter	Without SC	With SC Improvement
Ripple Current	45 A	33 A 70–82% ↓
Voltage Dip	14.8%	4.9% 66% ↓
Thermal Rise	+8°C	+2.1°C 74% ↓

Two scenarios were examined in terms of V2V energy transfer performance: (i) a battery design without a supercapacitor (SC) and (ii) a battery configuration with one. The simulation findings demonstrate that in the absence of a supercapacitor, electric vehicles' Li-ion batteries are subjected to voltage and power exchange fluctuations due to the high peak current demand caused by fast load changes. As a result, there is more strain, the SOC decreases more quickly, and the stability of energy transmission is diminished.

A more even distribution of electricity amongst vehicles is achieved by the efficient absorption of transient peaks made possible by SC integration. The Li-ion battery can provide constant energy thanks to the hybrid storage structure, while the SC can provide high-power bursts as needed. Battery life is increased, thermal burden is decreased, and dependability is improved by observing the current and voltage profiles. Consequently, the supercapacitor-based V2V setup is a viable option for rapid energy transfer between EVs.

**FEATURE SCOPE:**

This study lays the groundwork for future improvements to V2V charging systems, however there are still many opportunities for growth and advancement in real-time:

In order to further optimise the coordination between SC and batteries, advanced control algorithms like MPC, FLC, ANFIS, or RL-based energy management may be used.

The use of hybrid SC-battery ultracapacitor banks or graphene-based EDLCs may increase the energy density of supercapacitors. Adding predictive controllers based on machine learning can further decrease stress during dynamic load changes.

**REFERENCES**

[1] J. Yuan, L. Dorn-Gomba, A. D. Callegaro, J. Reimers, and A. Emadi, "A review of bidirectional on-board chargers for electric vehicles," *IEEE Access*, vol. 9, pp. 51501–51518, 2021.

[2] M. Y. Metwly, M. S. Abdel-Majeed, A. S. Abdel-Khalik, R. A. Hamdy, M. S. Hamad, and S. Ahmed, "A review of integrated on-board EV battery chargers: Advanced topologies, recent developments and optimal selection of FSCW slot/pole combination," *IEEE Access*, vol. 8, pp. 85216–85242, 2020.

[3] A. Khaligh and M. D'Antonio, "Global trends in high-power on-board chargers for electric vehicles," *IEEE Trans. Veh. Technol.*, vol. 68, no. 4, pp. 3306–3324, Apr. 2019.

[4] V. T. Tran, D. Sutanto, and K. M. Muttaqi, "The state of the art of battery charging infrastructure for electrical vehicles: Topologies, power control strategies, and future trend," in *Proc. Australas. Universities Power Eng. Conf. (AUPEC)*, Nov. 2017, pp. 1–6.

[5] M. R. Khalid, I. A. Khan, S. Hameed, M. S. J. Asghar, and J.-S. Ro, "A comprehensive review on structural topologies, power levels, energy storage systems, and standards for electric vehicle charging stations and their impacts on grid," *IEEE Access*, vol. 9, pp. 128069–128094, 2021.

[6] M. Yilmaz and P. T. Krein, "Review of battery charger topologies, charging power levels, and infrastructure for plug-in electric and hybrid vehicles," *IEEE Trans. Power Electron.*, vol. 28, no. 5, pp. 2151–2169, May 2013.

[7] G. Li, L. Boukhatem, L. Zhao, and J. Wu, "Direct vehicle-to-vehicle charging strategy in vehicular Ad-Hoc networks," in *Proc. 9th IFIP Int. Conf. New Technol., Mobility Secur. (NTMS)*, Jan. 2018, pp. 1–5.

[8] R. Q. Zhang, X. Cheng, and L. Q. Yang, "Flexible energy management protocol for cooperative EV-to-EV

charging," *IEEE Trans. Intell. Transp. Syst.*, vol. 20, no. 1, pp. 172–184, Jan. 2019

[9] D. M. Mughal, J. S. Kim, H. Lee, and M. Y. Chung, "Performance analysis of V2V communications: A novel scheduling assignment and data transmission scheme," *IEEE Trans. Veh. Technol.*, vol. 68, no. 7, pp. 7045–7056, Jul. 2019.

[10] E. Bulut and M. C. Kisacikoglu, "Mitigating range anxiety via vehicle-to-vehicle social charging system," in *Proc. IEEE 85th Veh. Technol. Conf. (VTC Spring)*, Jun. 2017, pp. 1–5.

[11] P. You and Z. Yang, "Efficient optimal scheduling of charging station with multiple electric vehicles via V2V," in *Proc. IEEE Int. Conf. Smart Grid Commun. (SmartGridComm)*, Nov. 2014, pp. 716–721.

